

Full name _____

Boat make/model _____ LOA _____ ft

Email _____

Rigg Sloop Cutter 7/8 9/10 3/4

Number of reefs 1 2 3

Foot loose with foot rope diam. _____ mm

Design full batten 2+2 1+3 no batten

Pre-band Mast, (no backstay tension)

Main band middle upper part

Distance main halyard to mast under tension:

H= _____ cm G= _____ cm F= _____ cm

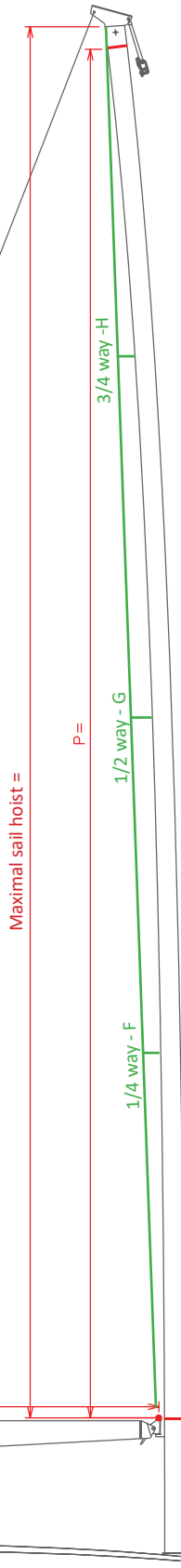
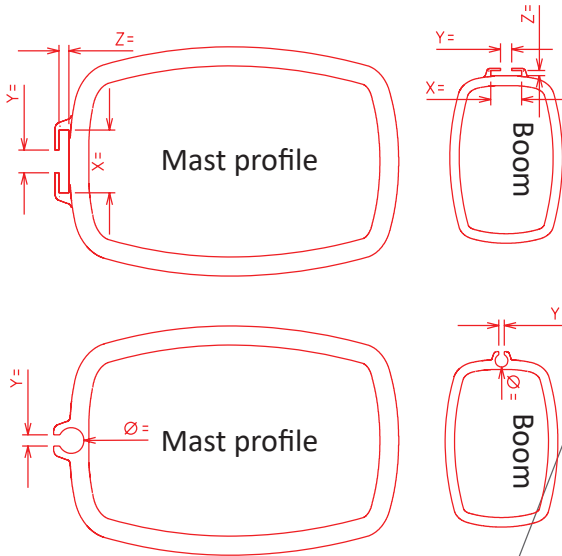

FORM: MAINSAIL (W/WO BEND)

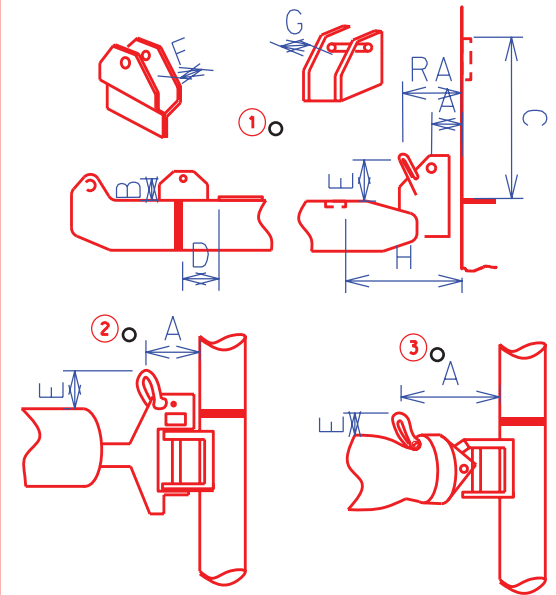

Choose the Gooseneck (1, 2 or 3)

- A= _____ cm
- B= _____ cm
- C= _____ cm
- D= _____ cm
- E= _____ cm
- F= _____ cm
- G= _____ cm
- RA = _____ cm

Slides

Internal		
Selden Kemp		
Groove		

Full batten cart
 Rutgerson © 1530
 (recommended for boats up to 50ft LOA)

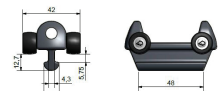

Example 1530-11-xxE

More option available on: <https://www.rutgerson.se/product/battcar-with-m10-stainless-steel-thread/>
 Indicate Rutgerson item number

